

WARNING! - Please Read this Information Carefully:

The project described in these pages utilizes **POTENTIALLY FATAL HIGH VOLTAGES**. If you are in any way unfamiliar with high voltage circuits or are uncomfortable working around high voltages, **PLEASE DO NOT RISK YOUR LIFE BY BUILDING THEM**. Seek help from a competent technician before building any unfamiliar electronics circuit. While efforts are made to ensure accuracy of these circuits, no guarantee is provided, of any kind!

USE AT YOUR OWN RISK: THE WEBMASTER, PROJECT COORDINATOR, PROJECT CONTRIBUTORS AND WEB SPACE PROVIDER EXPRESSLY DISCLAIM ALL LIABILITY FOR INJURY OR PROPERTY DAMAGE RESULTING FROM THIS INFORMATION! ALL INFORMATION IS PROVIDED 'AS-IS' AND WITHOUT WARRANTY OF ANY KIND.

COPYRIGHT AND INTELLECTUAL PROPERTY NOTICE:

The content of this document is protected by the copyright laws of the United States of America and the international copyright laws and agreements.

Except where specifically noted, Cliff Chappell or Chris Hurley owns (or has permission to use) all intellectual property rights in relation to this document and its content (including, but not limited to, all trademarks and copyright).

No part of the document may be reproduced, displayed, copied, translated, adapted, downloaded, broadcast, used or republished in any form including (without limitation) distribution, or storage in a system for retrieval.

Revision	Description
08.08.03	Removed Rx1 and Changed Rx2 To 56K
08.10.02	Change D1 To UF4007 Removed R20 & R21 Changed VR4 To 25KB Changed C13 To 0.68uF/100V Changed VR6 To 250KB Change VR7 To 1MA Changed VR8 to 25KB Changed Tonestack Wiring Changed C16 To 0.022uF Changed V3 To 12AY7
08.10.06	Changed R14 & R15 To 5k6 Added Alternate Tonestack
08.10.22	Made S2 Standby Optional
08.11.15	Removed Alternate Preamp Added Optional Output Transformer Detail

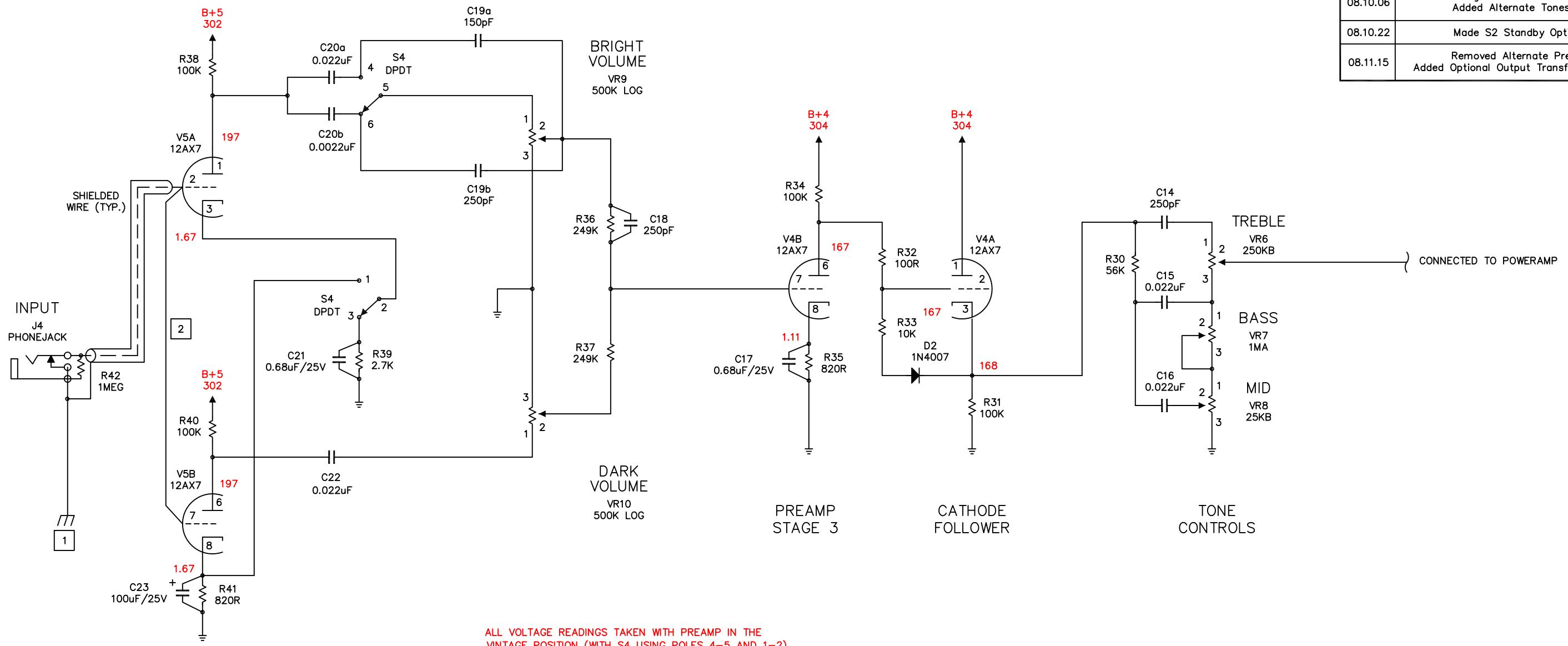

PREAMP
STAGE 1 AND 2

PREAMP
STAGE 3

CATHODE
FOLLOWER

TRIPLE
CONTROLS

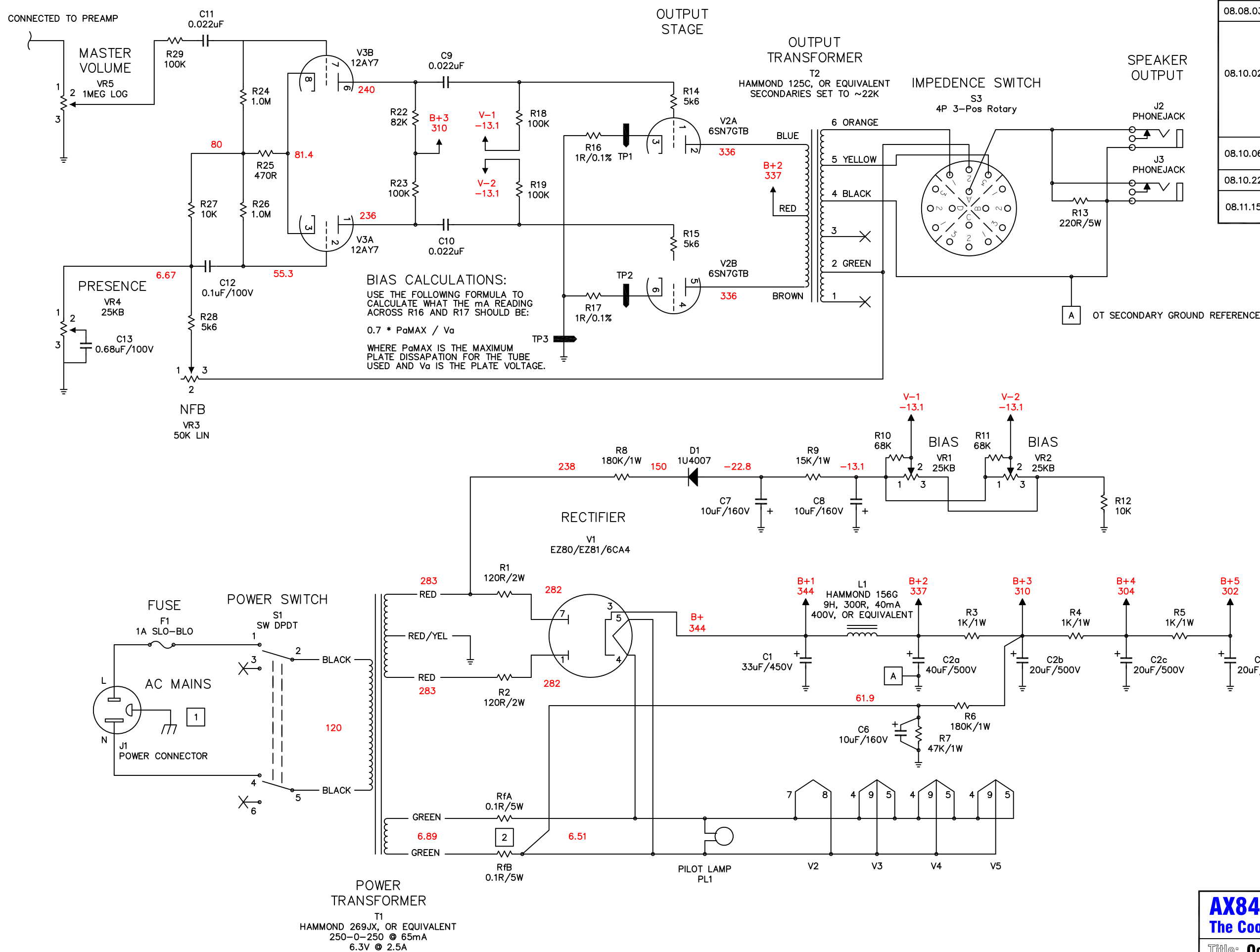

Revision	Description
08.08.03	Removed Rx1 and Changed Rx2 To 56K
08.10.02	Change D1 To UF4007 Removed R20 & R21 Changed VR4 To 25KB Changed C13 To 0.68uF/100V Changed VR6 To 250KB Change VR7 To 1MA Changed VR8 to 25KB Changed Tonestack Wiring Changed C16 To 0.022uF Changed V3 To 12AY7
08.10.06	Changed R14 & R15 To 5k6 Added Alternate Tonestack
08.10.22	Made S2 Standby Optional
08.11.15	Removed Alternate Preamp Added Optional Output Transformer Detail

Revision	Description
08.08.03	Removed Rx1 and Changed Rx2 To 56K
08.10.02	Change D1 To UF4007 Removed R20 & R21 Changed VR4 To 25KB Changed C13 To 0.68uF/100V Changed VR6 To 250KB Change VR7 To 1MA Changed VR8 to 25KB Changed Tonestack Wiring Changed C16 To 0.022uF Changed V3 To 12AY7
08.10.06	Changed R14 & R15 To 5k6 Added Alternate Tonestack
08.10.22	Made S2 Standby Optional
08.11.15	Removed Alternate Preamp Added Optional Output Transformer Detail

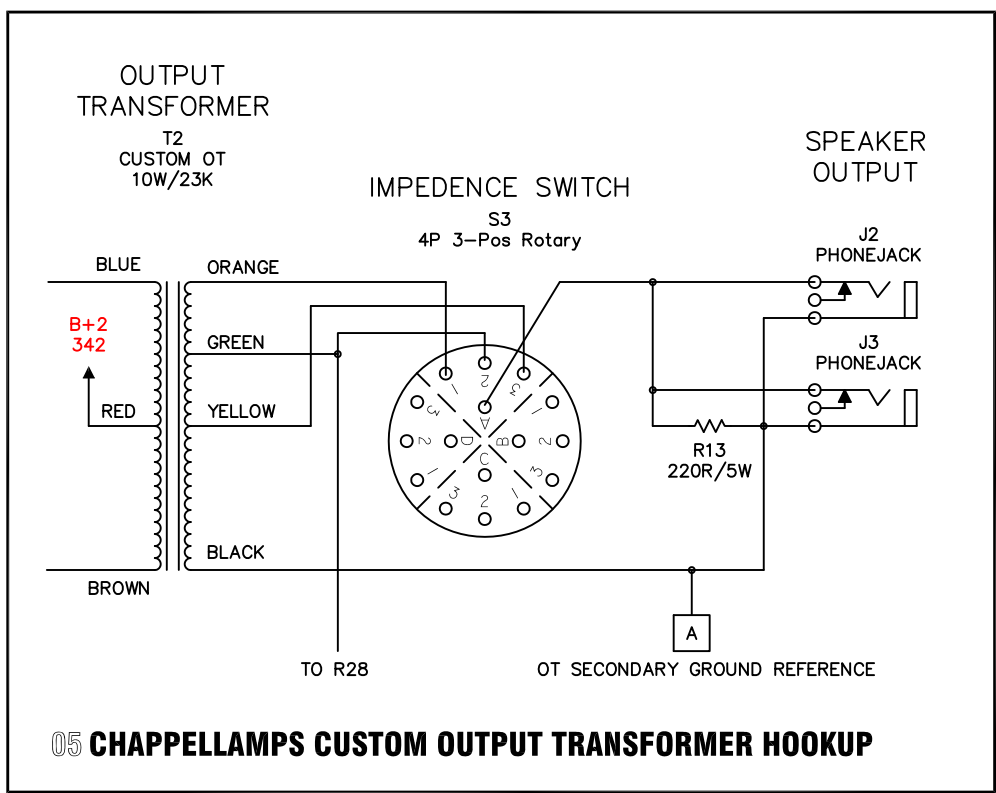
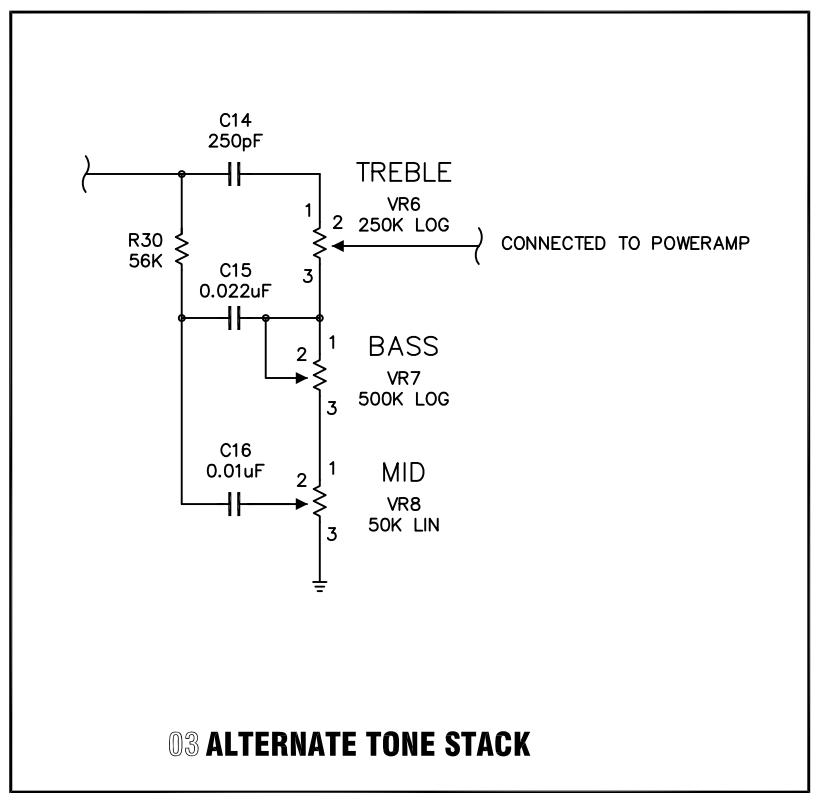
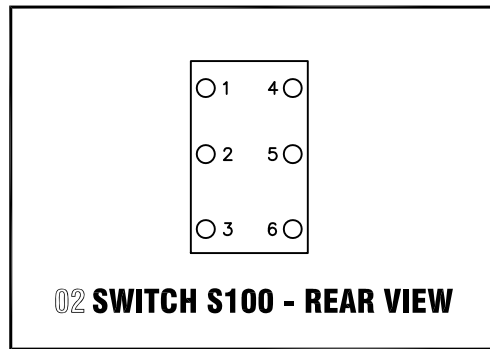
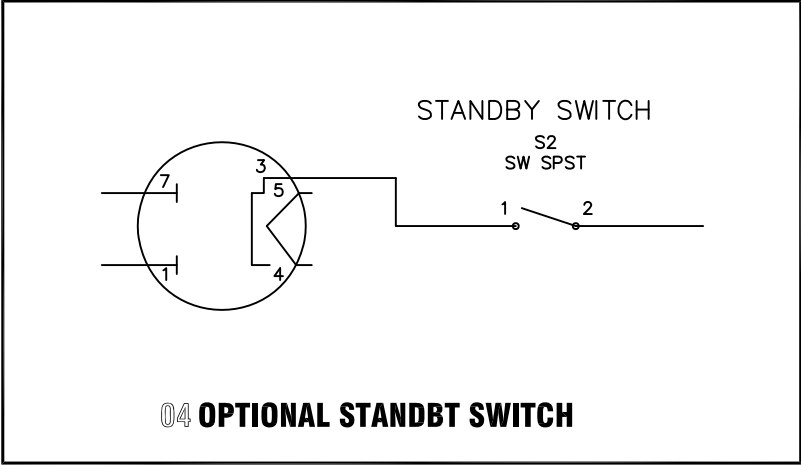
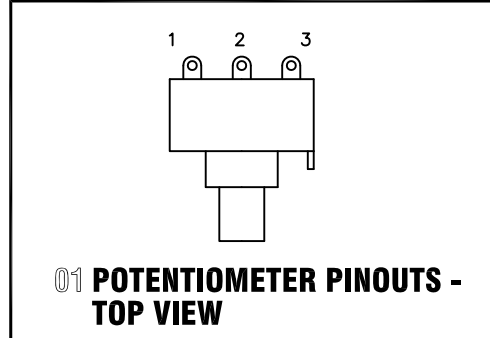

GENERAL NOTES:

1. ALL RESISTORS 1/2W MINIMUM UNLESS OTHERWISE NOTED.
2. ALL COUPLING CAPACITORS 400V OR GREATER.
3. VOLTAGE READINGS ARE THOSE TAKEN WITH MY TUBE SET. THE USE OF DIFFERENT TUBE SETS WILL ALTER THE READINGS.
4. A 12AV7 TUBE MAY BE USED IN THE V3 POSITION TO LOWER THE GAIN OF THE PI AND REDUCE DISTORTION.

CONSTRUCTION NOTES:

1. THIS IS A GROUND CONNECTION TO THE CHASSIS. THE MAINS SAFETY CONNECTION SHOULD BE MADE AS CLOSE AS POSSIBLE TO THE POINT WHERE AC ENTERS THE CHASSIS. THE CIRCUIT CONNECTION SHOULD BE MADE AS CLOSE AS POSSIBLE TO THE INPUT JACK. IDEALLY, THE JACK ITSELF SHOULD BE USED AS THE CONNECTION POINT BY NOT ISOLATING IT FROM THE CHASSIS.
2. THESE TWO 0.1R/5W RESISTORS ARE OPTIONAL, AND ARE NEEDED ONLY WHEN YOUR MAINS VOLTAGES ARE GREATER THAN THAT WHICH THE POWER TRANSFORMER WAS WOUND FOR. THE VALUES SHOWN SHOULD BE CORRECT FOR A 115V PT USED WITH 120V MAINS. THE PURPOSE OF THESE TWO RESISTORS IS TO INSURE THAT THE FILAMENT VOLTAGE STAYS WITHIN +/- 10% OF 6.3VAC.

VOLTAGE READING NOTES:

1. THE VOLTAGE READINGS ON THIS SCHEMATIC ARE SIMULATED BASED ON THE USE OF A HAMMOND 269JX WITH 120V MAINS.
2. DIFFERENT TUBES DRAW DIFFERENT AMOUNTS OF CURRENT, NO TWO ARE ALIKE UNLESS THEY ARE MATCHED. THE AMOUNT OF CURRENT DRAWN BY ALL THE TUBES IN THE AMP WILL AFFECT VOLTAGE READINGS THROUGHOUT THE AMP.

AX84 October Studio Amplifier BOM

Revision: 08.11.15

Item	Quantity	Reference	Value
1	1	C1	33uF/450V
2	1	C2	40/20/20/20 Multi-section Capacitor
3	3	C6, C7, C8	10uF/160V
4	7	C9, C10, C11, C15, C16, C20a, C22	0.022uF/400V
5	1	C12	0.1uF/100V
6	1	C13	0.68uF/100V
7	3	C14, C18, C19b	250pF/500V
8	2	C17, C21	0.68uF/25V
9	1	C19a	150pF/500V
10	1	C20b	0.0022uF/400V
11	1	C23	100uF/25V
12	2	R1, R2	120R/2W
13	2	Rfa, Rfb	0.1R/5W
14	3	R3, R4, R5	1K/1W
15	2	R6, R8	180K/1W
16	1	R7	47K/1W
17	1	R9	15K/1W
18	2	R10, R11	68K
19	3	R12, R27, R33	10K
20	1	R13	220R/5W
21	3	R14, R15, R28	5k6
22	2	R16, R17	1R/0.1%
23	8	R18, R19, R23, R29, R31, R34, R38, R40	100K
24	1	R22	82K
25	2	R36, R37	249K
26	3	R24, R26, R42	1.0M
27	1	R25	470R
28	1	R30	33K
29	1	R32	100R
30	1	R35, R41	820R
31	1	R39	2k7
32	1	F1	1A SLO-BLO
33	1	FH1	Fuse Holder
34	1	J1	Power Connector
35	3	J2, J3, J4	Phonejack
36	4	JW1, JW2, JW3, JW4	Phonejack Isolation Washer (if needed)
37	2	S1, S4	SW DPDT
38	1	S3	4P 3-Pos Rotary (Shorting)
39	2	D1, D2	UF4007
40	1	PL1	Pilot Lamp Assembly And Bulb
41	1	T1	Hammond 269JX
42	1	T2	Hammond 125C
43	1	L1	Hammond 156G
44	4	SK1, SK3, SK4, SK5	9 Pin Tube Sockets

45	1	SK2	8 Pin Octal Socket
46	1	V1	EZ80/EZ81/6CA4
47	1	V2	6SN7GTB
48	1	V3	12AY7
49	2	V4, V5	12AX7
50	2	VR1, VR2	25KB (bias)
51	1	VR3	50K LIN
52	2	VR4, VR8	25KB
53	2	VR5, VR7	1MEG LOG
54	1	VR6	250KB
55	2	VR9, VR10	500K LOG
56	1	CCImp	Clamp For Multi-section Cap C2
57	8	K1, K2, K3, K4, K5, K6, K7, K8	Knobs
58	1	CH1	Chassis
59	1	PWC1	Power Cord
60	2	TP1, TP2	Red Tip Jack
61	1	TP3	Black Tip Jack

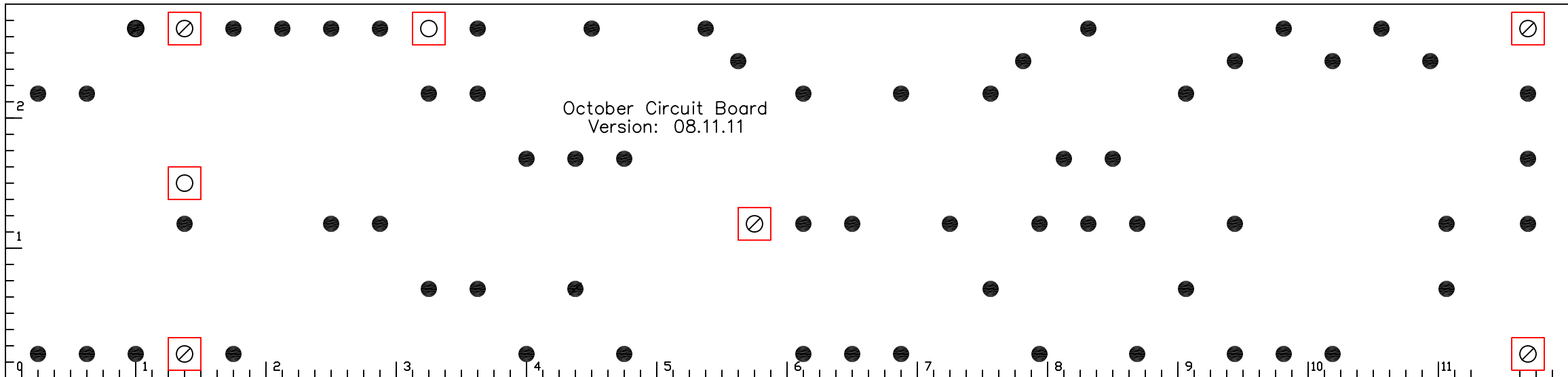

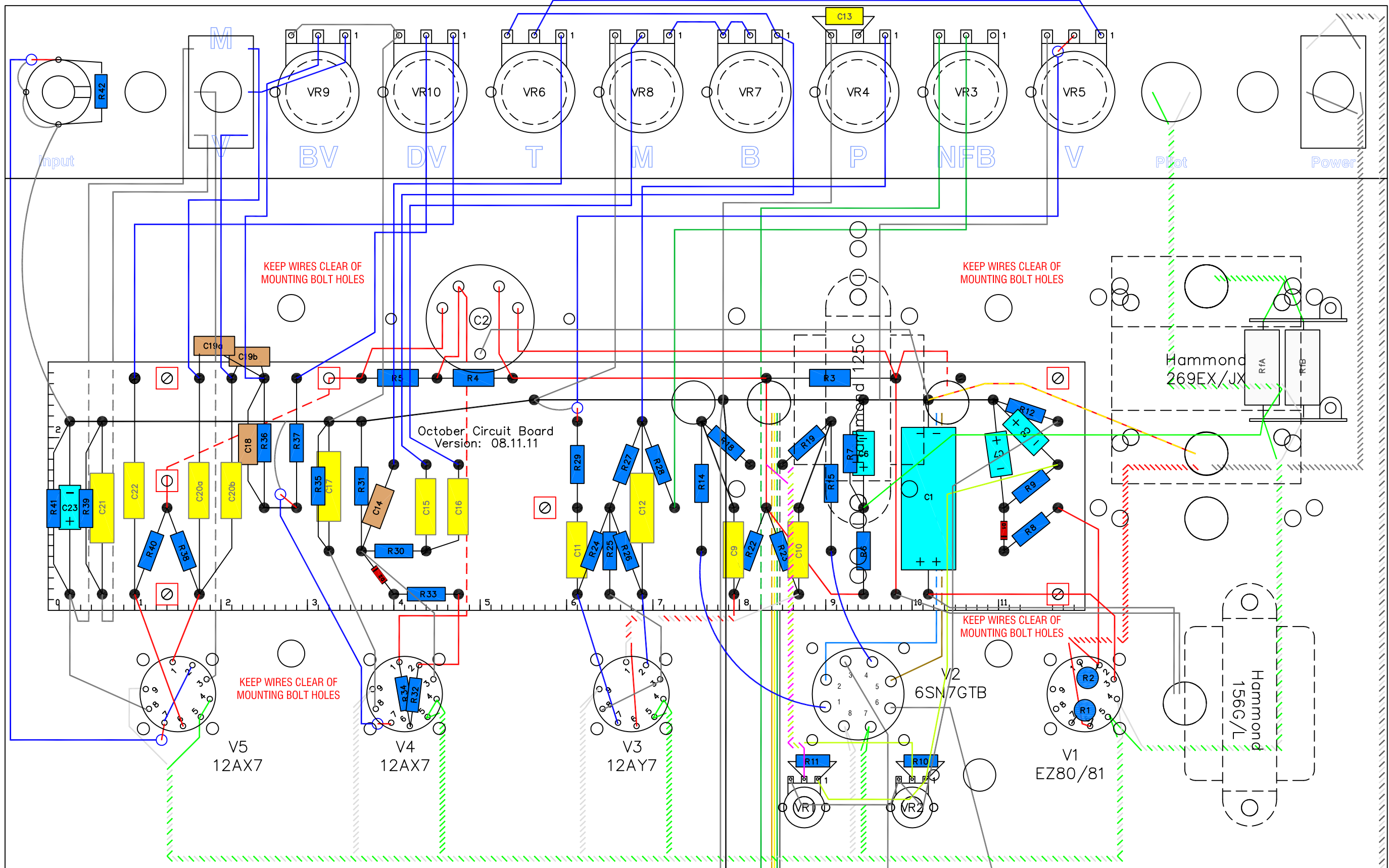

AX84 October ~ Studio Chassis Layout

Version: 08.11.15

AX84 Kit Chassis 1

Version: 08.05.07

